

इंटरनेट

मानक

### Disclosure to Promote the Right To Information

Whereas the Parliament of India has set out to provide a practical regime of right to information for citizens to secure access to information under the control of public authorities, in order to promote transparency and accountability in the working of every public authority, and whereas the attached publication of the Bureau of Indian Standards is of particular interest to the public, particularly disadvantaged communities and those engaged in the pursuit of education and knowledge, the attached public safety standard is made available to promote the timely dissemination of this information in an accurate manner to the public.

“जानने का अधिकार, जीने का अधिकार”

Mazdoor Kisan Shakti Sangathan

“The Right to Information, The Right to Live”

“पुराने को छोड़ नये के तरफ”

Jawaharlal Nehru

“Step Out From the Old to the New”

IS 4923 (1997): Hollow steel sections for structural use - Specification [MTD 19: Steel Tubes, Pipes and Fittings]

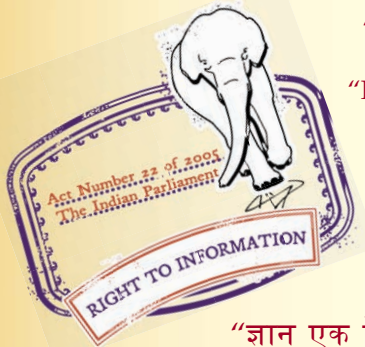

“ज्ञान से एक नये भारत का निर्माण”

Satyanarayan Gangaram Pitroda

“Invent a New India Using Knowledge”



“ज्ञान एक ऐसा खजाना है जो कभी चुराया नहीं जा सकता है”

Bhartrhari—Nitiśatakam

“Knowledge is such a treasure which cannot be stolen”

भारतीय मानक  
खोखले इस्पात के खंड संरचनात्मक  
प्रयोग के लिये — विशिष्टि  
( दूसरा पुनरीक्षण )

*Indian Standard*

**HOLLOW STEEL SECTIONS FOR  
STRUCTURAL USE — SPECIFICATION**  
( *Second Revision* )

ICS 77.140.75

© BIS 1997

**BUREAU OF INDIAN STANDARDS**  
MANAK BHAVAN, 9 BHADUR SHAH ZAFAR MARG  
NEW DELHI 110002

## FOREWORD

This Indian Standard (Second Revision) was adopted by the Bureau of Indian Standards, after the draft finalized by the Steel Tubes, Pipes and Fittings Sectional Committee had been approved by the Metallurgical Engineering Division Council.

This standard was first published in 1968 and was revised in 1985. In view of the recent developments in the use of hollow steel sections for structural use, the committee decided to revise this standard incorporating the following main modifications :

- a) Table 1 has been modified to cover sizes of square hollow sections presently being used.
- b) Table 2 has been modified to cover sizes of rectangular hollow sections presently being used in the country.
- c) References have been updated.
- d) Various clauses have been aligned with the present practice being followed.

For the purpose of deciding whether a particular requirement of this standard is complied with, the final value, observed or calculated, expressing the result of a test or analysis, shall be rounded off in accordance with IS 2 : 1960 'Rules for rounding off numerical values (*revised*)'. The number of significant places retained in the rounded off value should be the same as that of the specified value in this standard.

**AMENDMENT NO. 1 DECEMBER 1998**  
**TO**  
**IS 4923 : 1997 HOLLOW STEEL SECTIONS FOR**  
**STRUCTURAL USE — SPECIFICATION**  
*(Second Revision)*

(Page 2, Fig. 1) — Substitute the following figure for the existing figure:

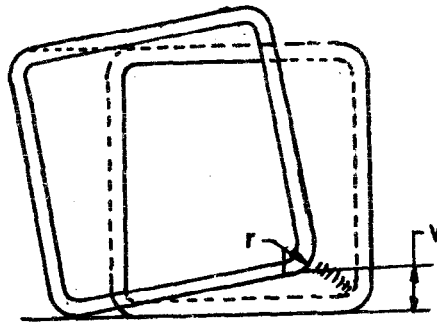

$r_{\text{Max}}$  = Maximum permitted outside corner radius in mm.  
 $V$  = Total measured twist in millimetres.

FIG. 1 MEASUREMENT OF TWIST OF SQUARE AND RECTANGULAR SECTIONS

(MTD 19)

**AMENDMENT NO. 2 MAY 2005  
TO  
IS 4923 : 1997 HOLLOW STEEL SECTIONS FOR  
STRUCTURAL USE — SPECIFICATION**

*( Second Revision )*

( Page 5, Table 1 ) — Insert the following at the end:

**Table 1 Dimension and Properties of Square Hollow Sections**

*( Clause 8.1 and Note in Annex A )*

Designation	Depth or Width <i>D</i>	Thickness	Weight	Area of Section	Moment of Inertia	Radius of Gyration	Elastic Modulus	Plastic Modulus
mm	mm	mm	kg/m	cm <sup>2</sup>	cm <sup>4</sup>	cm	cm <sup>3</sup>	cm <sup>3</sup>
(1)	(2)	(3)	(4)	(5)	(6)	(7)	(8)	(9)
180 × 180 × 4	180	4	21.9	27.9	1 434	7.17	159	184
180 × 180 × 5	180	5	27.2	34.6	1 755	7.12	195	226
180 × 180 × 6	180	6	32.05	40.83	2 036	7.06	226	280
180 × 180 × 8	180	8	42.5	54.1	2 633	6.98	293	346

( MTD 19 )

Reprography Unit, BIS, New Delhi, India

**AMENDMENT NO. 3 APRIL 2008  
TO  
IS 4923 : 1997 HOLLOW STEEL SECTIONS FOR  
STRUCTURAL USE — SPECIFICATION**

*( Second Revision )*

*(Page 2, clause 9, Title)* — Substitute 'STRAIGHTNESS, TWIST AND CONCAVITY/CONVEXITY' for 'STRAIGHTNESS AND TWIST'

*(Page 2, clause 9.2)* — Insert the following new clause after 9.2:

**9.3 Concavity and Convexity**

The concavity  $x_1$  or the convexity  $x_2$  of the sides of a square or rectangular hollow section shall be measured as shown in Fig. 2. The percentage concavity or convexity shall be calculated as follows:

$$\frac{x_1}{B} \times 100, \frac{x_2}{B} \times 100, \frac{x_1}{H} \times 100, \frac{x_2}{H} \times 100$$

where  $B$  and  $H$  are the lengths of the sides containing the concavity  $x_1$  or the convexity  $x_2$ .

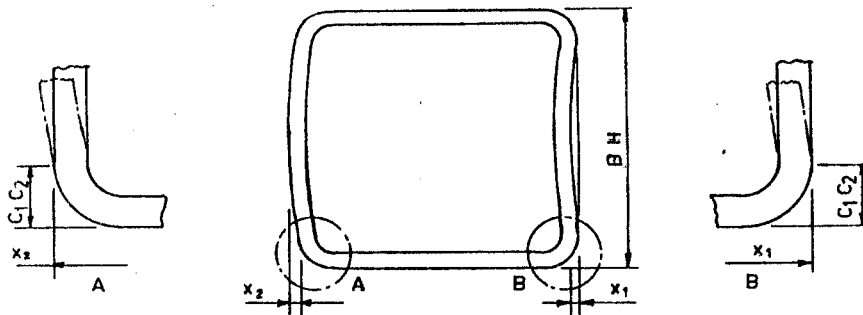

$C_1, C_2$  = length of external corner profile of a square or rectangular hollow section in mm.

**FIG. 2 MEASUREMENT OF CONCAVITY/CONVEXITY OF SQUARE OR RECTANGULAR HOLLOW SECTIONS**

**Amend No. 3 to IS 4923 : 1997**

*(Page 2, clause 13.1, tabular matter)* — Insert the following at the end:

'g) Concavity/convexity 1 percent of the size'

*(Page 3, clauses 13.1 and 17.1, tabular matter)* — Insert the following at the end:

'g) Concavity/convexity 1 percent of the size'

(MTD 19)

**AMENDMENT NO. 4 JULY 2008  
TO  
IS 4923 : 1997 HOLLOW STEEL SECTIONS FOR  
STRUCTURAL USE — SPECIFICATION**

*( Second Revision )*

*[Page 5, Table 1 (see also Amendment No. 2)] — Substitute  
'Designation/Size' for 'Designation'.*

*(Page 6, Table 2) — Substitute 'Designation/Size' for 'Designation'.*

(MTD 19)

---

Reprography Unit, BIS, New Delhi, India

**AMENDMENT NO. 5 JUNE 2010**  
**TO**  
**IS 4923 : 1997 HOLLOW STEEL SECTIONS FOR**  
**STRUCTURAL USE — SPECIFICATION**

*( Second Revision )*

*(Page 2, clause 9.1, para 2)* — Delete.

*(Page 2, clause 12.1)* — Substitute the following for the existing:

‘Manufacturer name/Logo/Trade-mark shall be embossed on each hollow section. Each hollow section shall have size designation suitably marked on it.’

*[Page 3, clause 17.1(c)(2)]* — Substitute ‘10 tonnes, *Min*’ for 10 tonnes’.

(MTD 19)

---

Reprography Unit, BIS, New Delhi, India

**AMENDMENT NO. 6 JUNE 2011**  
**TO**  
**IS 4923 : 1997 HOLLOW STEEL SECTIONS FOR STRUCTURAL USE —**  
**SPECIFICATION**

*( Second Revision )*

*(Page 2, clause 10)* — Substitute the following for the existing:

**‘10 COATING**

**10.1** Hollow sections may be varnished, painted or oiled externally or may be galvanized as agreed between the purchaser and the manufacturer. In case of galvanizing, the mass of zinc coating shall be as per the agreement between the manufacturer and purchaser.’

(MTD 19)

## *Indian Standard*

# HOLLOW STEEL SECTIONS FOR STRUCTURAL USE — SPECIFICATION

### 1 SCOPE

1.1 This standard covers the requirements for hot and cold formed square and rectangular hollow steel sections for structural use.

### 2 REFERENCES

The following Indian Standards are necessary adjuncts to this standard:

<i>IS No.</i>	<i>Title</i>
228	Methods of chemical analysis of pig iron, cast iron and plain carbon and low alloy steels
1387 : 1993	General requirements for the supply of metallurgical materials ( <i>second revision</i> )
1608 : 1995	Mechanical testing of metals — Tensile testing ( <i>second revision</i> )

### 3 TERMINOLOGY

3.0 For the purpose of this standard, the following definitions shall apply.

#### 3.1 Black Section

Section as manufactured, but without any subsequent surface treatment.

#### 3.2 Exact Length

Specified length of a single section as mentioned by the purchaser.

#### 3.3 Random Length

Normal manufacturing lengths which may vary over a range of several metres. Alternatively, a length range agreed to between the manufacturer and the purchaser.

#### 3.4 Section

When used without qualification it refers to one length of square or rectangular hollow section covered by this specification.

### SECTION 1 GENERAL REQUIREMENTS

### 4 SUPPLY OF MATERIAL

4.1 General requirements relating to the supply of steel hollow sections shall conform to IS 1387.

### 5 DESIGNATION

5.1 A hollow section shall be designated by its outside dimensions and its thickness in millimetres and shall be further classified into CF or HF depending upon whether it is cold formed or hot formed.

*Examples:*

- a) A hot formed square hollow section with outside dimensions of 50 mm square and 2.90 mm thickness is designated as 50 × 50 × 2.90 HF SHS.
- b) A cold formed square hollow section with outside dimensions of 50 mm square and 2.90 mm thickness is designated as 50 × 50 × 2.90 CF SHS.
- c) A hot formed rectangular hollow sectional with outside dimensions of 40 mm depth, 25 mm breadth and 2.65 mm thickness is designated as 40 × 25 × 2.65 HF RHS.

### 6 MANUFACTURE

6.1 The hollow sections shall be manufactured from steel made by any approved process which, shall show not more than 0.050 percent of sulphur and not more than 0.050 percent of phosphorus.

NOTE — The copper bearing steel may be used in manufacturing the sections subject to mutual agreement between the manufacturer and the purchaser. Copper content to range between 0.20 to 0.35 percent.

6.1.1 The analysis of steel shall be carried out either by the methods specified in IS 228 and its relevant parts or any other established instrumental/chemical method. In case of dispute the procedure given in IS 228 and its relevant parts shall be the referee method.

6.2 Tubes for forming into square and rectangular hollow sections shall be manufactured by one of the following processes :

- a) Seamless,
- b) Hot finished welded, or
- c) Electric resistance or induction welded.

### 7 BASIS OF CALCULATION

7.1 For the purpose of the standard, the weights are calculated on the basis that steel weighs 0.785 kg/cm<sup>2</sup> per metre run. For calculating cross-

sectional area and weight per unit length, corner radii have taken into consideration (see Annex A).

## 8 DIMENSIONS AND WEIGHTS

8.1 The standard sizes and weights of hollow sections with other geometrical properties shall be as given in Tables 1 and 2 (see pages 5 and 6). Sizes other than those given in Tables 1 and 2 may be supplied by mutual agreement between the supplier and the purchaser.

## 9 STRAIGHTNESS AND TWIST

9.1 The tubes shall be supplied either in finish straightened or mill straightened condition as agreed to between the purchaser and the manufacturer for which maximum deviation from straightness shall be as under. For tubes in finish straightened condition 1/600th of length at the centre of the length.

For tubes in mill straightened condition 1/200th of any length at the centre of the length.

9.2 Twist shall be measured for square and rectangular sections as given in Fig. 1. The tolerances on twist shall be 2 mm plus 0.5 mm/m measured in accordance with the figure.

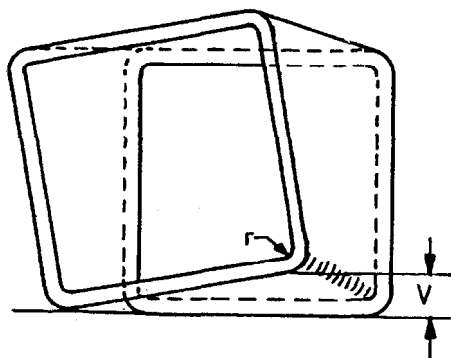

$r_{max}$  = Maximum permitted outside corner radius in mm.  
 $V$  = Total measured twist in millimetres.

FIG. 1 MEASUREMENT OF TWIST OF SQUARE AND RECTANGULAR SECTIONS

## 10 OILING AND PAINTING

10.1 Hollow sections may be varnished painted or oiled externally, if so agreed between the purchaser and the supplier.

## 11 PACKING

11.1 Where hollow sections are to be bundled for transport, these shall, unless otherwise specified, be secured together by rope, soft wire or straps. If other packing is required, it shall be agreed to between the purchaser and the manufacturer.

## 12 MARKING

12.1 Each hollow section shall have the name of the manufacturer and size designation suitably marked on it. Alternatively, a label containing the particulars may be attached to a bundle of hollow sections.

12.1.1 Other particulars required by the purchaser may be suitably marked as mutually agreed.

### 12.2 BIS Certification Marking

Hollow sections may also be marked with the Standard Mark.

12.2.1 The use of the Standard Mark is governed by the provisions of *Bureau of Indian Standard Act, 1986* and the rules and regulations made there under the details of conditions under which the licence for the use of the Standard Mark may be granted to manufacturers or producers may be obtained from the Bureau of Indian Standards.

## SECTION 2 SPECIFIC REQUIREMENTS FOR HOT FORMED SECTIONS

## 13 TOLERANCES

13.1 The following tolerances shall be permitted on hot formed hollow sections :

- |    |                             |   |
|----|-----------------------------|---|
| a) | Thickness for all sizes     |   |
|    | 1) Welded tubes             | $\pm 10$ percent  |
|    | 2) Seamless tubes           | + 17.5 percent<br>- 12.5 percent  |
| b) | Outside dimensions of sides | $\pm 1$ percent of length of the side to be measured with a minimum of $\pm 0.5$ mm |
| c) | Weight                      | + 10 percent<br>- 8 percent   |
|    | 1) On individual length     | $\pm 7.5$ percent   |
|    | 2) On lots of 10 tonnes     | $90^\circ \pm 2^\circ$  |
| d) | Squareness of corner        |   |
| e) | Radii of corners — Outside  | $3t$ , max where $t$ is the thickness of section                                    |
| f) | Length                      |   |
|    | 1) Exact length             | $\pm 6$ mm  |
|    | 2) Random length            | This may be obtained by arrangement between the purchaser and manufacturer          |

## 14 MECHANICAL TESTS

14.1 One tensile test shall be carried out for each batch of 500 hollow sections.

14.2 When tested in accordance with IS 1608, the tensile properties would be as shown in Table 3. Elongation on a gauge length of  $5.65 \sqrt{A}$  (where  $A$  is the cross-sectional area of test specimen) shall be as in Table 3.

**Table 3 Tensile Properties of Hot Formed Sections**

Grade	Tensile Strength, Min, MPa	Yield Stress, Min, MPa	Elongation, percent, Min
YSt 210	330	210	20
YSt 240	410	240	15
YSt 310	450	310	10

NOTE — For welded tubes, the strip tensile test specimen shall not include the weld.

### 15 RETEST

15.1 Should any one of the test pieces selected fail to pass the test specified under 14, two further samples shall be selected for testing in respect of each failure. Should the test pieces from both these additional samples pass, the material shall be deemed to comply with the requirements of the test. Should the test pieces from either of these additional samples fail, the material represented by the test samples shall be deemed as not complying with this standard.

## SECTION 3 SPECIFIC REQUIREMENTS FOR COLD FORMED SECTIONS

### 16 CONDITION OF SUPPLY

16.1 The section shall be supplied in as welded condition. The section may also be stress relieved, annealed or normalized as agreed between manufacturer and purchaser.

### 17 TOLERANCES

17.1 The following tolerances shall be permitted on cold formed hollow sections :

- a) Thickness all sizes  $\pm 10$  percent
- NOTES
- 1 The measurement of thickness should exclude the weld zone.
- 2 The height of the internal weld fin shall not exceed 60 percent of the wall thickness.
- b) Outside dimensions  $\pm 1$  percent with a minimum of  $\pm 0.5$  mm
- c) Weight
- 1) On individual lengths  $+ 10$  percent  
 $- 8$  percent
- 2) On lots of 10 tonnes  $\pm 7.5$  percent
- d) Squareness of corner  $90^\circ \pm 2^\circ$
- e) Radii of corners —  $3t$ , Max where  $t$  is the thickness of the section

### f) Length

- 1) Exact length  $\pm 6$  mm
- 2) Random length These may be obtained by arrangement between the purchaser and the manufacturer

## 18 MECHANICAL TESTS

18.1 One tensile test shall be carried out for each of 500 hollow sections.

18.2 When tested in accordance with IS 1608, the tensile properties of cold formed sections and elongation percentage on a gauge length of  $5.65 \sqrt{A}$  (where  $A$  is the cross-sectional area of the section) shall be as in Table 4.

NOTE — The tensile test piece should be taken excluding the side of the section on which the weld seam exists.

**Table 4 Tensile Properties of Cold Formed Sections (Clause 18.2)**

Grade	Tensile Strength, Min, mPa	Yield Stress, Min, mPa	Elongation, percent, Min for Sizes	
			<sup>1)</sup> 25.4 and under	<sup>1)</sup> Over 25.4
YSt 210	330	210	12	20
YSt 240	410	240	10	15
YSt 310	450	310	8	10

<sup>1)</sup>The value shall be applicable for the smaller side of the rectangular section.

18.3 If sections supplied in cold formed condition without any heat treatment are subjected to stress relieving, annealing, brazing, welding or similar heating, the mechanical properties may be reduced at the heated parts as follows :

Grade	Tensile Strength, Min, MPa	Yield Stress, Min, MPa
YSt 210	230	140
YSt 240	310	170
YSt 310	350	240

### 19 RETEST

19.1 Should any of the pieces selected fail to pass the test specified under 18, two further samples shall be selected for testing in respect of each failure. Should the test pieces from both of these additional samples pass, the material shall be deemed to comply with the requirements of the test. Should the test pieces from either of these additional samples fail, the material represented by the test samples shall be deemed as not complying with this standard.

## ANNEX A

( Clause 7.1 )

## GEOMETRICAL DATA OF HOLLOW SECTIONS

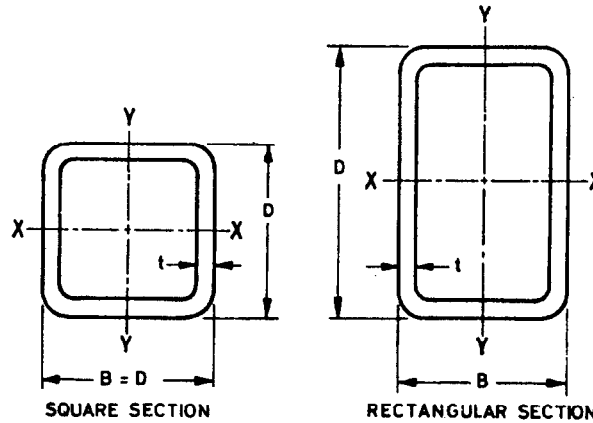

$$\text{Area of cross-section} = A = 2t [(B - 4t) + (D - 4t)] + \frac{3}{2} \pi t \text{ in cm}^2$$

$$\text{Weight (kg/m)} = W = 0.785 A \text{ in cm}^2$$

For X - X axis :

$$\begin{aligned} \text{Moment of inertia} = I_x &= t \frac{(D - 4t)^3}{6} + \frac{1}{2} \left[ \frac{(B - 4t) t^3}{3} + (B - 4t) (D - t)^2 t \right] + \\ &\frac{\pi t^4}{108} \left[ 405 - \frac{3 \cdot 136}{\pi^2} \right] + 3 \pi t^2 \left[ \frac{9 \pi (D - 4t) + 56t}{18 \pi} \right]^2 \text{ in cm}^4 \end{aligned}$$

$$\text{Elastic modulus} = Z_x = \frac{2 I_x}{D} \text{ in cm}^3$$

$$\text{Plastic modulus} = S_x = t/2 (D - 4t)^2 + t (B - 4t) (D - t) + \frac{t^2}{6} [9 \pi (D - 4t) + 56 t] \text{ in cm}^3$$

$$\text{Radius of gyration} = R_x = \sqrt{\frac{I_x}{A}} \text{ in cm}$$

For Y - Y axis :

$$\begin{aligned} \text{Moment of inertia} = I_y &= \frac{t (B - 4t)^3}{6} + \frac{1}{2} \left[ \frac{(D - 4t) t^3}{3} + (D - 4t) (B - t)^2 t \right] + \\ &\frac{\pi t^4}{108} \left[ 405 - \frac{3 \cdot 136}{\pi^2} \right] + 3 \pi t^2 \left[ \frac{9 \pi (B - 4t) + 56t}{18 \pi} \right]^2 \text{ in cm}^4 \end{aligned}$$

$$\text{Elastic modulus} = Z_y = \frac{2 I_y}{B} \text{ in cm}^3$$

$$\text{Plastic modulus} = S_y = t/2 (B - 4t)^2 + t (D - 4t) (B - t) + \frac{t^2}{6} [9 \pi (B - 4t) + 56 t] \text{ in cm}^3$$

$$\text{Radius of gyration} = R_y = \sqrt{\frac{I_y}{A}} \text{ in cm}$$

NOTE — Letter symbols denoting various dimensions are the same as those used in Tables 1 and 2.

**Table 1 Dimensions and Properties of Square Hollow Sections**  
(Clause 8.1 and Note in Annex A)

Designation	Depth or Width <i>D</i>	Thick-ness	Weight	Area of Section	Moment of Inertia	Radius of Gyration	Elastic Modulus	Plastic Modulus
mm (1)	mm (2)	mm (3)	kg/m (4)	cm <sup>2</sup> (5)	cm <sup>4</sup> (6)	cm (7)	cm <sup>3</sup> (8)	cm <sup>3</sup> (9)
25.0 × 25.0 × 2.6	25.0	2.6	1.69	2.16	1.72	0.89	1.38	1.76
25.0 × 25.0 × 3.2	25.0	3.2	1.98	2.53	1.89	0.86	1.51	1.98
30.0 × 30.0 × 2.6	30.0	2.6	2.10	2.68	3.23	1.10	2.15	2.68
30.0 × 30.0 × 3.2	30.0	3.2	2.49	3.17	3.62	1.07	2.41	3.08
30.0 × 30.0 × 4.0	30.0	4.0	2.94	3.75	3.97	1.03	2.64	3.50
32.0 × 32.0 × 2.6	32.0	2.6	2.26	2.88	4.02	1.18	2.51	3.11
32.0 × 32.0 × 3.2	32.0	3.2	2.69	3.42	4.54	1.15	2.84	3.59
32.0 × 32.0 × 4.0	32.0	4.0	3.19	4.07	5.02	1.11	3.14	4.11
35.0 × 35.0 × 2.6	35.0	2.6	2.51	3.20	5.43	1.30	3.10	3.81
35.0 × 35.0 × 3.2	35.0	3.2	2.99	3.81	6.18	1.27	3.53	4.42
35.0 × 35.0 × 4.0	35.0	4.0	3.57	4.55	6.93	1.23	3.96	5.11
38.0 × 38.0 × 2.6	38.0	2.6	2.75	3.51	7.14	1.43	3.76	4.57
38.0 × 38.0 × 2.9	38.0	2.9	3.03	3.86	7.68	1.41	4.04	4.97
38.0 × 38.0 × 3.2	38.0	3.2	3.29	4.19	8.18	1.40	4.30	5.34
38.0 × 38.0 × 3.6	38.0	3.6	3.63	4.62	8.76	1.38	4.61	5.80
38.0 × 38.0 × 4.0	38.0	4.0	3.95	5.03	9.26	1.36	4.87	6.22
40.0 × 40.0 × 2.6	40.0	2.6	2.92	3.72	8.45	1.51	4.22	5.12
40.0 × 40.0 × 3.2	40.0	3.2	3.49	4.45	9.72	1.48	4.86	6.01
40.0 × 40.0 × 3.6	40.0	3.6	3.85	4.91	10.45	1.46	5.22	6.53
40.0 × 40.0 × 4.0	40.0	4.0	4.20	5.35	11.07	1.44	5.54	7.01
45.0 × 45.0 × 2.6	45.0	2.6	3.32	4.24	12.47	1.71	5.52	6.64
45.0 × 45.0 × 2.9	45.0	2.9	3.66	4.67	13.45	1.70	5.98	7.25
45.0 × 45.0 × 3.2	45.0	3.2	3.99	5.09	14.41	1.68	6.40	7.83
45.0 × 45.0 × 3.6	45.0	3.6	4.42	5.63	15.57	1.66	6.92	8.55
45.0 × 45.0 × 4.5	45.0	4.5	5.31	6.77	17.74	1.62	7.88	9.99
49.5 × 49.5 × 2.9	49.5	2.9	4.07	5.19	18.37	1.88	7.42	8.93
49.5 × 49.5 × 3.6	49.5	3.6	4.93	6.28	21.42	1.85	8.66	10.60
49.5 × 49.5 × 4.5	49.5	4.5	5.95	7.58	24.64	1.80	9.96	12.47
63.5 × 63.5 × 3.2	63.5	3.2	5.85	7.45	44.35	2.44	13.97	16.65
63.5 × 63.5 × 3.6	63.5	3.6	6.51	8.29	48.55	2.42	15.29	18.36
63.5 × 63.5 × 4.5	63.5	4.5	7.93	10.10	57.00	2.38	17.95	21.93
72.0 × 72.0 × 3.2	72.0	3.2	6.71	8.54	66.32	2.79	18.42	21.80
72.0 × 72.0 × 4.0	72.0	4.0	8.22	10.47	79.03	2.75	21.95	26.32
72.0 × 72.0 × 4.8	72.0	4.8	9.66	12.31	90.31	2.71	25.09	30.49
75.0 × 75.0 × 3.2	75.0	3.2	7.01	8.93	75.53	2.91	20.41	23.79
75.0 × 75.0 × 4.0	75.0	4.0	8.59	10.95	90.19	2.87	24.05	28.76
75.0 × 75.0 × 4.9	75.0	4.9	10.30	13.12	104.82	2.83	27.95	33.92
88.9 × 88.9 × 3.6	88.9	3.6	9.38	11.95	142.83	3.46	32.13	37.85
88.9 × 88.9 × 4.5	88.9	4.5	11.52	14.67	170.97	3.41	38.46	45.85
88.9 × 88.9 × 4.9	88.9	4.9	12.44	15.85	182.57	3.39	41.07	49.23
91.5 × 91.5 × 3.6	91.5	3.6	9.67	12.32	156.49	3.56	34.21	40.24
91.5 × 91.5 × 4.5	91.5	4.5	11.88	15.14	187.57	3.52	41.00	48.79
91.5 × 91.5 × 5.4	91.5	5.4	14.01	17.85	215.68	3.48	47.14	56.77
100.0 × 100.0 × 4.0	100.0	4.0	11.73	14.95	226.35	3.89	45.27	53.30
100.0 × 100.0 × 5.0	100.0	5.0	14.41	18.36	271.10	3.84	54.22	64.59
100.0 × 100.0 × 6.0	100.0	6.0	16.98	21.63	311.47	3.79	62.29	75.10
113.5 × 113.5 × 4.5	113.5	4.5	14.99	19.10	372.88	4.42	65.71	77.33
113.5 × 113.5 × 4.8	113.5	4.8	15.92	20.28	393.31	4.40	69.30	81.81
113.5 × 113.5 × 5.4	113.5	5.4	17.74	22.60	432.58	4.38	76.23	90.55
113.5 × 113.5 × 6.0	113.5	6.0	19.53	24.87	469.81	4.35	82.79	98.96
125.0 × 125.0 × 4.5	125.0	4.5	16.62	21.17	505.83	4.89	80.93	94.84
125.0 × 125.0 × 5.0	125.0	5.0	18.33	23.36	552.62	4.86	88.42	104.10
125.0 × 125.0 × 6.0	125.0	6.0	21.69	27.63	640.89	4.82	102.54	121.87
132.0 × 132.0 × 4.8	132.0	4.8	18.71	23.83	634.39	5.16	96.12	112.69
132.0 × 132.0 × 5.4	132.0	5.4	20.88	26.59	700.11	5.13	106.08	125.02
132.0 × 132.0 × 6.0	132.0	6.0	23.01	29.31	762.98	5.10	115.60	136.98
150.0 × 150.0 × 5.0	150.0	5.0	22.26	28.36	982.12	5.89	130.95	152.98
150.0 × 150.0 × 6.0	150.0	6.0	26.40	33.63	1145.91	5.84	152.79	179.88

**Table 2 Dimensions and Properties of Rectangular Hollow Sections**  
(Clause 8.1 and Note in Annex A)

Designation	Depth of Section <i>D</i>	Width of Section <i>B</i>	Thick- ness	Weight	Area of Section	Moment of Inertia About		Radius of Gyration About		Elastic Modulus About		Plastic Modulus About	
						X-X cm <sup>4</sup>	Y-Y cm <sup>4</sup>	X-X cm	Y-Y cm	X-X cm <sup>3</sup>	Y-Y cm <sup>3</sup>	X-X cm <sup>3</sup>	Y-Y cm <sup>3</sup>
mm (1)	mm (2)	mm (3)	mm (4)	Kg/m (5)	cm <sup>2</sup> (6)	(7)	(8)	(9)	(10)	(11)	(12)	(13)	(14)
50.0 × 25.0 × 2.9	50.0	25.0	2.9	2.98	3.80	10.93	3.60	1.70	0.97	4.37	2.88	5.72	3.48
50.0 × 25.0 × 3.2	50.0	25.0	3.2	3.24	4.13	11.63	3.80	1.68	0.96	4.65	3.04	6.14	3.73
60.0 × 40.0 × 2.9	60.0	40.0	2.9	4.12	5.25	24.74	13.11	2.17	1.58	8.25	6.56	10.25	7.73
66.0 × 33.0 × 2.9	66.0	33.0	2.9	4.07	5.19	27.33	9.12	2.29	1.33	8.28	5.53	10.59	6.49
66.0 × 33.0 × 3.6	66.0	33.0	3.6	4.93	6.28	31.87	10.52	2.25	1.29	9.66	6.37	12.56	7.66
66.0 × 33.0 × 4.5	66.0	33.0	4.5	5.95	7.58	36.64	11.93	2.20	1.25	11.10	7.23	14.77	8.94
70.0 × 30.0 × 2.9	70.0	30.0	2.9	4.12	5.25	29.82	7.72	2.38	1.21	8.52	5.14	11.07	6.04
70.0 × 30.0 × 3.2	70.0	30.0	3.2	4.50	5.73	32.04	8.24	2.37	1.20	9.15	5.49	11.98	6.51
70.0 × 30.0 × 4.0	70.0	30.0	4.0	5.45	6.95	37.23	9.42	2.31	1.16	10.64	6.28	14.20	7.66
80.0 × 40.0 × 2.9	80.0	40.0	2.9	5.03	6.41	50.87	17.11	2.82	1.63	12.72	8.56	16.07	9.88
80.0 × 40.0 × 3.2	80.0	40.0	3.2	5.50	7.01	54.94	18.41	2.80	1.62	13.74	9.21	17.46	10.72
80.0 × 40.0 × 4.0	80.0	40.0	4.0	6.71	8.55	64.79	21.49	2.75	1.59	16.20	10.74	20.91	12.77
96.0 × 48.0 × 3.2	96.0	48.0	3.2	6.71	8.54	98.61	33.28	3.40	1.97	20.54	13.87	25.85	15.91
96.0 × 48.0 × 4.0	96.0	48.0	4.0	8.22	10.47	117.54	39.32	3.55	1.94	24.49	16.30	31.21	19.14
96.0 × 48.0 × 4.8	96.0	48.0	4.8	9.66	12.31	134.35	44.55	3.30	1.90	27.99	18.56	36.13	22.08
100.0 × 50.0 × 3.2	100.0	50.0	3.2	7.01	8.93	112.29	37.95	3.55	2.06	22.46	15.18	28.20	17.37
100.0 × 50.0 × 4.0	100.0	50.0	4.0	8.59	10.95	134.14	44.95	3.50	2.03	26.83	17.98	34.10	20.93
122.0 × 61.0 × 3.6	122.0	61.0	3.6	9.67	12.32	232.61	78.83	4.34	2.35	38.13	25.84	47.71	29.42
122.0 × 61.0 × 4.5	122.0	61.0	4.5	11.88	15.14	278.94	93.78	4.29	2.49	45.73	30.75	57.85	35.56
122.0 × 61.0 × 5.4	122.0	61.0	5.4	14.01	17.85	320.83	107.03	4.24	2.45	52.60	35.09	67.29	41.22
127.0 × 50.0 × 3.6	127.0	50.0	3.6	9.34	11.89	227.08	52.05	4.37	2.09	35.76	20.82	45.95	23.70
127.0 × 50.0 × 4.6	127.0	50.0	4.6	11.69	14.89	276.33	62.46	4.31	2.05	43.52	24.98	56.66	29.04
145.0 × 82.0 × 4.8	145.0	82.0	4.8	15.92	20.28	555.16	228.50	5.23	3.36	76.57	55.73	94.93	63.93
145.0 × 82.0 × 5.4	145.0	82.0	5.4	17.74	22.60	610.85	250.59	5.20	3.33	84.26	61.12	105.07	70.66
172.0 × 92.0 × 4.8	172.0	92.0	4.8	18.71	23.83	917.13	346.91	6.20	3.82	106.64	75.41	132.08	85.61
172.0 × 92.0 × 5.4	172.0	92.0	5.4	20.88	26.59	1012.47	381.74	6.17	3.79	117.73	82.99	146.55	94.86

## Bureau of Indian Standards

BIS is a statutory institution established under the *Bureau of Indian Standards Act, 1986* to promote harmonious development of the activities of standardization, marking and quality certification of goods and attending to connected matters in the country.

### Copyright

BIS has the copyright of all its publications. No part of these publications may be reproduced in any form without the prior permission in writing of BIS. This does not preclude the free use, in the course of implementing the standard, of necessary details, such as symbols and sizes, type or grade designations. Enquiries relating to copyright be addressed to the Director (Publication), BIS.

### Review of Indian Standards

Amendments are issued to standards as the need arises on the basis of comments. Standards are also reviewed periodically; a standard along with amendments is reaffirmed when such review indicates that no changes are needed; if the review indicates that changes are needed, it is taken up for revision. Users of Indian Standards should ascertain that they are in possession of the latest amendments or edition by referring to the latest issue of 'BIS Handbook' and 'Standards Monthly Additions'

This Indian Standard has been developed from Doc: No. MTD 19 ( 4187 ).

#### Amendments Issued Since Publication

Amend No.	Date of Issue	Text Affected

## BUREAU OF INDIAN STANDARDS

### Headquarters:

Manak Bhavan, 9 Bahadur Shah Zafar Marg, New Delhi 110002  
Telephones: 323 01 31, 323 33 75, 323 94 02

Telegrams: Manaksanstha  
(Common to all offices)

### Regional Offices:

Telephone

Central : Manak Bhavan, 9 Bahadur Shah Zafar Marg  
NEW DELHI 110002

323 76 17, 323 38 41

Eastern : 1/14 C.I.T. Scheme VII M, V.I.P. Road, Maniktola  
CALCUTTA 700054

{ 337 84 99, 337 85 61  
{ 337 86 26, 337 91 20

Northern : SCO 335-336, Sector 34-A, CHANDIGARH 160022

{ 60 38 43  
{ 60 20 25

Southern : C.I.T. Campus, IV Cross Road, CHENNAI 600113

{ 235 02 16, 235 04 42  
{ 235 15 19, 235 23 15

Western : Manakalaya, E9 MIDC, Marol, Andheri (East)  
MUMBAI 400093

{ 832 92 95, 832 78 58  
{ 832 78 91, 832 78 92

Branches : AHMADABAD. BANGALORE. BHOPAL. BHUBANESHWAR.  
COIMBATORE. FARIDABAD. GHAZIABAD. GUWAHATI.  
HYDERABAD. JAIPUR. KANPUR. LUCKNOW. NAGPUR.  
PATNA. PUNE. THIRUVANANTHAPURAM.